

ELNet^{LTP} Energy meter & Electrical Powermeter



ELNet-LTP energy powermeter is a compact, highly accurate 0.2% (0.1% optional), three-phase powermeter, especially designed to meet the needs of power and energy measurement in any electrical installation for monitoring the parameters of electrical network.

ELNet-LTP includes history data logging and supports standard communication protocols BACnet and Modbus with simple integration into Building Management Systems over RS485 or Ethernet TCP/IP communication, the built in Web Browser turns the device to be even more user friendly solution.

An indispensable tool for the Building Engineer, it aids efficient use of electricity by showing Power Factor, Max and Min demand, Current in Neutral Line, Harmonics up to 64th, periodic Energy and very important safety tool - a leakage current.

Technical Data

Power Requirements:	90 ~ 250 VAC 110 ~ 280 VDC 60/50 Hz 9VA
Dimensions (HxWxD):	96 x 96 x 80 mm
Shipping Weight:	0.65 Kg.
Environmental:	
Operation.	-20 ~ +70 °C
Storage.	-20 ~ +70 °C
Humidity	0 ~ 95 RH% non-condensing
Front Panel Protection	IP64

Communication

RS485 port:	Up to 115200 bauds Modbus and BACnet
Ethernet (TCP/IP):	Web browser capability

Input & Output Rating

Accuracy:	Active energy 0.1-0.2% Reactive energy 0.1-0.2%
Voltage: Line-Line	0 ~ 950 VAC RMS
Line-Neutral	0 ~ 550 VAC RMS
Maximum Burden	1000V RMS Continuous < 0.06VA
Current: Rated	0-1 A or 0-5 A
Overload	50 A RMS Continuous
Withstand Burden	100 A for 1 minute < 0.05 VA
Display:	High resolution color LCD display 320x240 pixels
Maximum Input Voltage:	1000V
Maximum Input Current:	6A
Digital inputs:	2, 230VAC (ON)
Digital output:	1, dry contact maximum load 150mA

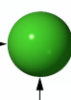

CONTROL APPLICATIONS Ltd.

Supervision & control system

Tel: +972-3-6474998 Fax: +972-3-6474598 24a Habarzel St. Tel-Aviv, 69710, Israel

Measurement & Display Values in direct connection

Measurement Parameter	Display Range in direct connection (scaling factor 1)	Measuring in direct connection (scaling factor 1)	Display Range
Current	0.001 – 6A	0.001 – 6A	0.001 – 99999KA
Neutral Current	0.001 – 6A	0.001 – 6A	0.001 – 99999KA
Voltage L-N	0.000 – 550 V	0.000 – 550 V	0.001 – 99999KV
Voltage L-L	0.000 – 550 V	0.000 – 550 V	0.001 – 99999KV
Frequency (Hz)	45.001-65.001 Hz	45.001-65.001 Hz	45.001-65.001 Hz
Active power total\phase			0.000W – 99999MW
Reactive power total\phase			0.000VAR - 99999MVAR
Apparent power total\phase			0.000VA - 99999MVA
Power Factor (cap.\ind.)	-1.000 ÷ 1.000	-1.000 ÷ 1.000	-1.000 ÷ 1.000
Active Energy total\phase			0.001WH – 99999999MWH
Reactive Energy total\phase			0.001VARH - 99999999MVARH
Apparent Energy total\phase			0.001VAH - 99999999MVAH
Harmonic THD V\I			0.000 – 100%
Partial Harmonic V\I			0.000 – 100%
Operating hour meter			99999-HH:MM:SS

Standards

IEC 62053-22
 IEC 62053-23
 IEC 62052-11
 EN 55022, Class A, Amendments A1; A2
 EN 55024, Amendments A1; A2
 EN 61000-3-2, Class A
 EN 61000-3-3, Amendment A1
 IEC 61000-4-2
 IEC 61000-4-3
 IEC 61000-4-4
 IEC 61000-4-5
 IEC 61000-4-6
 ICE 61000-4-11
 BTL approve (MS/TP & IP)

Accuracy (FS):

Voltage	±0.2 %
Current	± 0.2%
Energy	± 0.2%
Power	± 0.4 %
Frequency	± 0.05%
Power Factor	± 0.5%

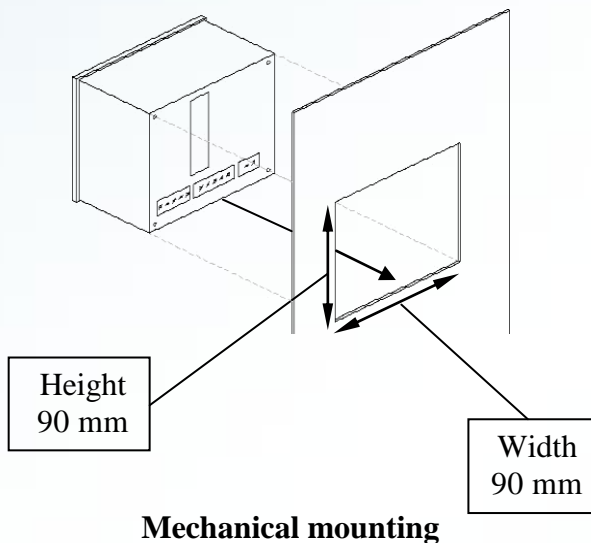

Mechanical mounting



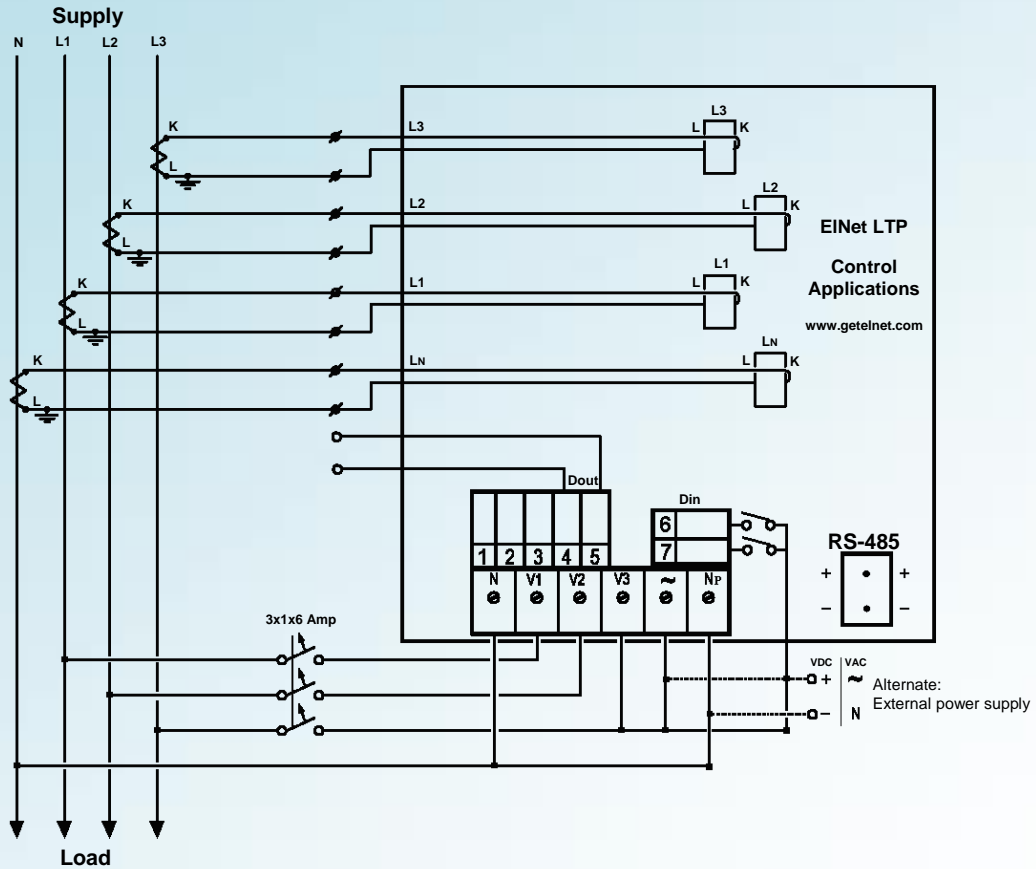

Wiring Diagram Example

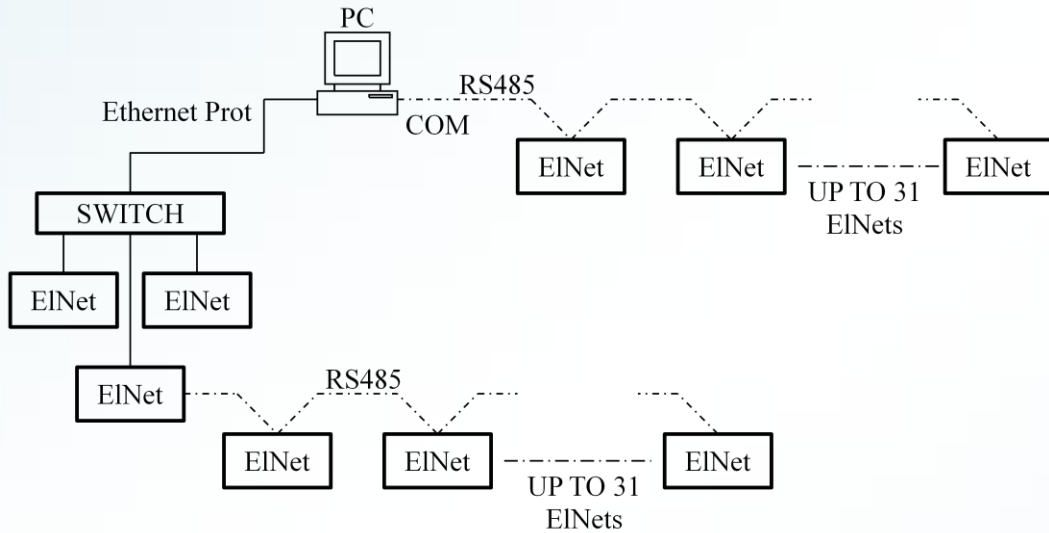

—— TCP/IP ETHERNET (Shielded & Grounded)

----- RS485 (Shielded & Grounded)

Communication Diagram Example

